

PROVISIONAL ANSWER KEY

| | |
|----------------------|-------------------|
| Question Paper Code: | 121/2026/OL |
| Category Code: | 470/2025 |
| Exam: | Mechanic |
| Date of Test | 11-06-2026 |
| Department | Medical Education |

Question1:-

What will happen if a multimeter set to current mode is connected directly across a voltage source?

A:-Accurate voltage reading will appear

B:-The source voltage will drop to zero

C:-A short circuit may occur

D:-The resistance will increase

Correct Answer:- Option-C

Question2:-A metric outside micrometer has a spindle pitch of 0.5 mm and a thimble divided into 50 equal graduations. During a calibration check against a standard block, the thimble reads 2 divisions below zero when the anvils are fully closed. What is the instrument's systematic error, and how should a subsequent reading be corrected ?

A:-

Negative zero error of 0.02 mm; subtract 0.02 mm from the observed reading

B:-

Positive zero error of 0.02 mm; subtract 0.02 mm from the observed reading

C:-

Negative zero error of 0.02 mm; add 0.02 mm to the observed reading

D:-Negative zero error of 0.01 mm; add 0.01 mm to the observed reading

Correct Answer:- Option-C

Question3:-An electrical engineer needs to secure a heavy terminal block to a copper busbar using an M6 x 1.0 metric coarse bolt. Utilizing the standard engineering approximation

formula for a standard 75% thread engagement, what diameter tap drill bit should be selected ?

A:-4.5 mm

B:-5.0 mm

C:-5.5 mm

D:-6.0 mm

Correct Answer:- Option-B

Question4:-Why should burrs be removed after cutting a conduit pipe ?

A:-To reduce wire insulation damage

B:-To increase pipe hardness

C:-To reduce bend radius

D:-To increase thread angle

Correct Answer:- Option-A

Question5:-The conductivity of a semiconductor generally

A:-Decreases with increase in temperature

B:-Remains constant

C:-Increases with increase in temperature

D:-Becomes zero at high temperature

Correct Answer:- Option-C

Question6:-

In an AC circuit, the RMS value of current represents

A:-Maximum current value

B:-Minimum current value

C:-Equivalent DC heating value

D:-Average current over half cycle only

Correct Answer:- Option-C

Question7:-Which tool is commonly used for cutting external threads on conduit pipes ?

A:-Reamer

B:-Pipe vice

C:-Hacksaw

D:-Die stock with dies

Correct Answer:- Option-D

Question8:-When making a splice joint between two electrical copper wires, what is the primary chemical function of applying soldering flux ?

A:-

To act as a strong adhesive cement that glues the plastic insulation jackets together.

B:-

To increase the electrical resistance of the joint to protect against lightning surges.

C:-To dissolve and remove surface oxide layers from the metal surfaces when heated, allowing the molten solder to wet and bond properly.

D:-To lower the electrical conductivity of the copper to match the solder alloy.

Correct Answer:- Option-C

Question9:-During the discharge of a basic primary Leclanché cell, hydrogen gas bubbles accumulate and form a thin layer around the carbon cathode. What is this phenomenon called ?

A:-Sulfation

B:-Local action

C:-Polarization

D:-Electrolysis

Correct Answer:- Option-C

Question10:-A magnetic flux of $400 \mu\text{Wb}$ passes perpendicularly through a steel core with a cross sectional area of $2 \text{ cm} \times 1 \text{ cm}$. Calculate the magnetic flux density (B) inside the core.

A:-0.5 T

B:-2.0 T

C:-5.0 T

D:-0.2 T

Correct Answer:- Option-B

Question11:-

The peak value of an AC current is 14.14 A. Its RMS value is

A:-20 A

B:-14.14 A

C:-10 A

D:-7.07 A

Correct Answer:- Option-C

Question12:-An electrical technician uses an oscilloscope to measure an AC voltage waveform and notes that a single complete cycle occupies exactly 20 milliseconds on the timebase grid. What is the cyclic frequency (f) of this electrical power source ?

A:-20 Hz

B:-50 Hz

C:-60 Hz

D:-500 Hz

Correct Answer:- Option-B

Question13:-An air-core toroidal inductor has N turns, mean radius R and cross-sectional area A. If the number of turns is doubled while all other physical dimensions remain unchanged, how does the self-inductance of the toroid change ?

A:-It remains unchanged

B:-

It becomes twice the original value

C:-It becomes four times the original value

D:-It becomes eight times the original value

Correct Answer:- Option-C

Question14:-Two capacitors, 10 μF and 20 μF , are each rated for a maximum voltage of 100 V. They are connected in series across a DC voltage source whose voltage is gradually increased. Which capacitor will reach its voltage rating first ?

A:-The 10 μF capacitor

B:-The 20 μF capacitor

C:-

Both capacitors will reach breakdown voltage simultaneously

D:-Neither capacitor will exceed its rating because the voltage divides equally

Correct Answer:- Option-A

Question15:-How does inserting a solid material with a high dielectric constant (such as mica) between the plates of an isolated, charged capacitor affect its capacitance and terminal voltage ?

A:-Capacitance increases and voltage increases

B:-Capacitance decreases and voltage decreases

C:-Capacitance increases and voltage decreases

D:-Capacitance and voltage both remain constant

Correct Answer:- Option-C

Question16:-In a series RLC circuit, what happens to the total impedance (Z) when the circuit operates exactly at its resonant frequency ?

A:-It reaches its maximum value

B:-It becomes minimum and equal to the resistance R

C:-

It becomes zero

D:-It becomes infinitely large

Correct Answer:- Option-B

Question17:-The total opposition offered by an AC circuit to the flow of current is called

A:-Conductance

B:-Reactance

C:-Admittance

D:-Impedance

Correct Answer:- Option-D

Question18:-The commutator in a DC motor acts as

A:-Mechanical rectifier

B:-AC generator

C:-Voltage stabilizer

D:-Capacitor

Correct Answer:- Option-A

Question19:-What is the primary cause of cogging torque (magnetic locking) in an electric motor, especially during starting or low-speed operation ?

A:-

High eddy currents produced in the armature core laminations

B:-Magnetic attraction between the stator teeth (slots) and rotor magnetic poles

C:-Incorrect brush alignment with the Magnetic Neutral Axis (MNA)

D:-Unbalanced three-phase power supply

Correct Answer:- Option-B

Question20:-A stepper motor converts

A:-Mechanical pulses into electrical signals

B:-Electrical pulses into discrete angular movement

C:-AC into DC

D:-Heat into rotation

Correct Answer:- Option-B

Question21:-What is the relationship between primary voltage (E_1 , V_1) and secondary voltage (E_2 , V_2) in a ideal transformer ?

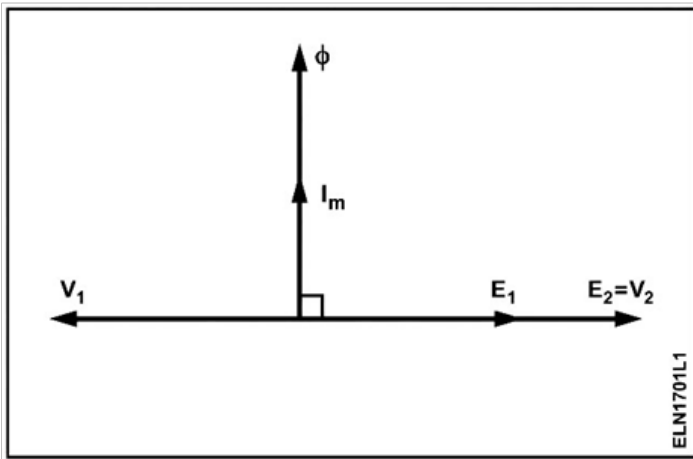

A: $-E_1 = V_1$ and $E_2 = V_2$

B: $-E_1 > V_1$ and $E_2 > V_2$

C: $-E_1 < V_1$ and $E_2 < V_2$

D: $-E_1 = V_2$ and $E_2 = V_1$

Correct Answer:- Option-A

Question22:-

Why the core of current transformer is having low reactance and low core losses ?

A:-To minimise the burden

B:-To maintain constant output

C:-To prevent high static shield

D:-

To minimise the error in reading

Correct Answer:- Option-D

Question23:-

What is the name of transformer ?

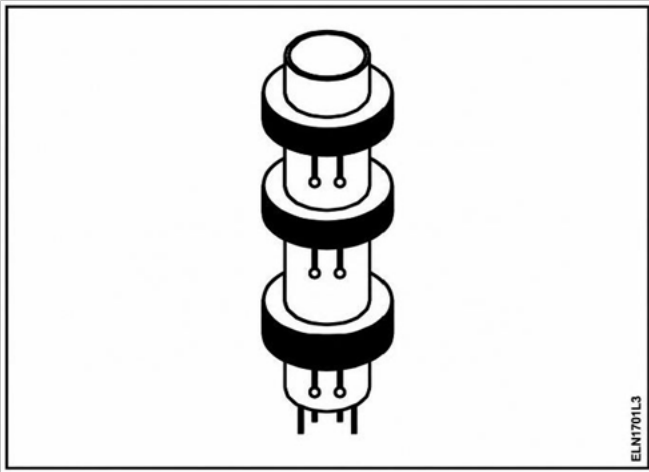

A:-Air core transformer

B:-Iron core transformer

C:-Ring core transformer

D:-Ferrite core transformer

Correct Answer:- Option-A

Question24:-What is the name of the scale ?

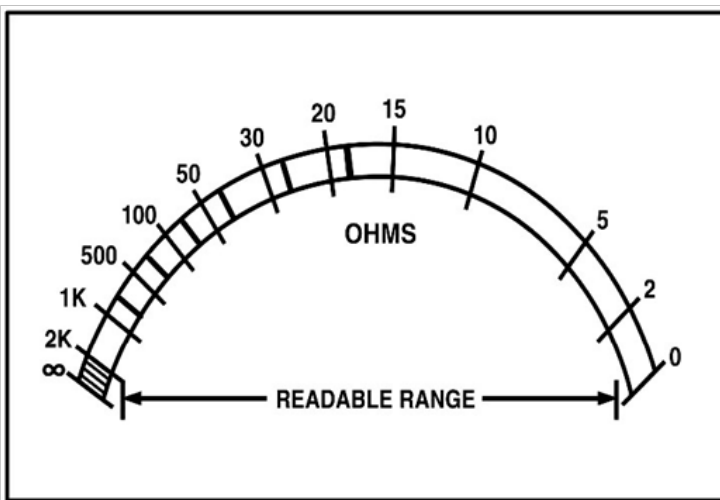

A:-Linear Scale

B:-Coarse scale

C:-Extended scale

D:-Non-linear scale

Correct Answer:- Option-D

Question25:-Which is an absolute instrument ?

A:-Ammeter

B:-Voltmeter

C:-Wattmeter

D:-Tangent galvanometer

Correct Answer:- Option-D

Question26:-Calculate the value of shunt resistance required to measure 10 mA with one mA and meter resistance 30 Ω .

A:-3 Ω

B:-30 Ω

C:-0.3 Ω

D:-300 Ω

Correct Answer:- Option-A

Question27:-Which instrument is used to measure one ohm and below one ohm resistance value accurately ?

A:-Megohm meter

B:-Multimeter (analog)

C:-Shunt type ohm meter

D:-Series type ohm meter

Correct Answer:- Option-C

Question28:-What is the name of the instrument ?

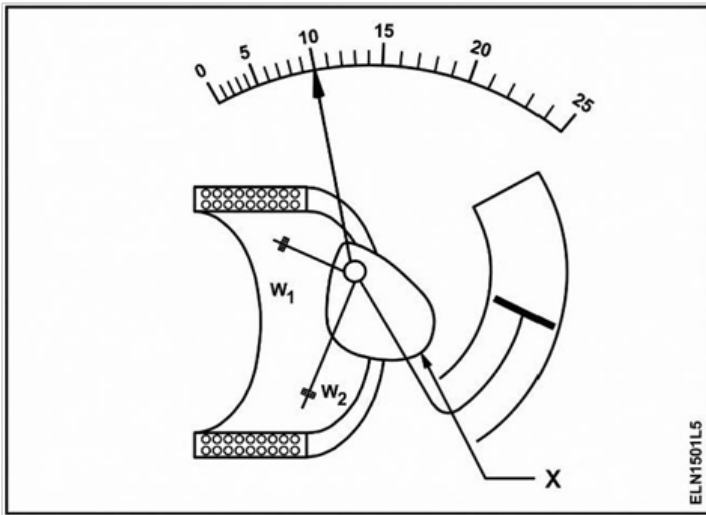

- A:-Attraction type moving iron
- B:-Repulsion type moving iron
- C:-Permanent magnet moving coil
- D:-Dynamo meter type moving coil

Correct Answer:- Option-A

Question29:-How can a dynamo meter type instrument be modified to function as a milliammeter or microammeter ?

- A:-By connecting the fixed coil and moving coil in parallel
- B:-By connecting the fixed coil and moving coil in series
- C:-By increasing the spring control torque
- D:-By adding a high resistance in series with the moving coil

Correct Answer:- Option-B

Question30:-

What is creeping in an energy meter ?

- A:-Rotation of the disc proportional to load current
- B:-Continuous slow rotation of the disc even when there is no load
- C:-Sudden stopping of the disc during heavy load
- D:-Reverse rotation of the disc due to wrong polarity connection

Correct Answer:- Option-B

Question31:-A domestic AC supply say 230 V is applied to a halfwave rectifier circuit through a transformer of turn ratio 10 : 1. Find the maximum Primary and Secondary voltage.

A:-162.65 V_{pm} and 16.26 V_{sm}

B:-325.3 V_{pm} and 32.53 V_{sm}

C:-262.43 V_{pm} and 26.24 V_{sm}

D:-372.14 V_{pm} and 37.21 V_{sm}

Correct Answer:- Option-B

Question32:-Which of the following statement is true ?

A:-Doping of pure Germanium with a trivalent impurity given n-type semiconductor

B:-Resistivity of pure Germanium increases with temperature

C:-Majority carriers in 'P' type semiconductor are holes

D:-Doping of pure Germanium with a pentavalent impurity increases its resistivity

Correct Answer:- Option-C

Question33:-The breakdown voltage of a Zener diode is 5 V. What is the resistance required to allow a current (I) of 100 mA through the Zener diode in reverse bias connected to a battery of emf 12 V ?

A:-50 Ω

B:-70 Ω

C:-100 Ω

D:-35 Ω

Correct Answer:- Option-B

Question34:-Which types of diode rectifier output double the input AC frequency of the pulsating DC ?

A:-Halfwave rectifier

B:-Fullwave bridge rectifier

C:-Two diode fullwave rectifier

D:-Two diode fullwave rectifier with filters

Correct Answer:- Option-C

Question35:-The output voltage range of regulator IC 723 is

A:-Between 1.25 V – 37V

B:-Between 1.35 V – 37 V

C:-Between 2 V – 37 V

D:-Between 0 V – 37 V

Correct Answer:- Option-C

Question36:-Gain of current gain in common collector amplifier is

A:-Low

B:-High

C:-Medium

D:-Very High

Correct Answer:- Option-B

Question37:-Which circuit is determined by the frequency variation of LC tank circuit ?

A:-Amplifier

B:-
Positive feedback amplifier

C:-
Summing amplifier

D:-Multiplexer

Correct Answer:- Option-B

Question38:-2N2646 is a code number of which component ?

A:-TRIAC

B:-MOSFET

C:-SCR

D:-UJT

Correct Answer:- Option-D

Question39:-Rate change of output voltage refers in operational amplifier is

A:-Slow Rate

B:-Sleew Rate

C:-Threshold Rate

D:-Slew Rate

Correct Answer:- Option-D

Question40:-What is the circuit function of 555 IC, while using in an Astable Multivibrator ?

A:-When triggered, it produces single output pulse of a set duration

B:-Switches between two stable states without an external trigger continuously

C:-To produce an output, it requires a continuous external trigger

D:-It converts an analog signal into digital signal and vice versa

Correct Answer:- Option-B

Question41:-The base of Octal number system is

A:-2

B:-8

C:-10

D:-16

Correct Answer:- Option-B

Question42:-In Boolean Algebra, $A + A$ equal to

A:-0

B:-1

C:-A

D:-None of these

Correct Answer:- Option-C

Question43:-Which gate gives inverted output ?

A:-AND

B:-OR

C:-XOR

D:-NOT

Correct Answer:- Option-D

Question44:-Register is madeup of using

A:-Diodes

B:-Flip-Flops

C:-Capacitors

D:-Resistors

Correct Answer:- Option-B

Question45:-Gray code is mainly used to

A:-Increase power

B:-Store images

C:-Increase memory

D:-Reduce errors

Correct Answer:- Option-D

Question46:-A Flip-Flop is a

A:-Memory element

B:-Oscillator

C:-Amplifier

D:-Resistor

Correct Answer:- Option-A

Question47:-Sampling theorem is related to

A:-DAC

B:-ADC

C:-Register

D:-Counter

Correct Answer:- Option-B

Question48:-Which gate is commonly used for difference output in subtractor ?

A:-AND

B:-OR

C:-XOR

D:-NOR

Correct Answer:- Option-C

Question49:-The deflection sensitivity of a CRO is expressed in

A:-Division/Volt

B:-Volt/Division

C:-cm/Volt

D:-Volt/cm

Correct Answer:- Option-C

Question50:-Which interrupt has the highest priority in 8085 microprocessor ?

A:-RST 7.5

B:-RST 6.5

C:-TRAP

D:-INTR

Correct Answer:- Option-C

Question51:-The output of a measurement system should ideally have

A:-High distortion

B:-High fidelity

C:-Zero sensitivity

D:-Infinite loading effect

Correct Answer:- Option-B

Question52:-The dynamic characteristics become important when

A:-Input remains constant

B:-Instrument is switched off

C:-Calibration is performed

D:-Input varies with time

Correct Answer:- Option-D

Question53:-An instrument may be precise but not accurate due to

A:-Random errors

B:-
Systematic errors

C:-
High sensitivity

D:-Measurement lag

Correct Answer:- Option-B

Question54:-The unit of strain is

A:-N/m

B:-Pascal

C:-Meter

D:-No unit

Correct Answer:- Option-D

Question55:-Which is the operating principle of Eddy current tachometers ?

A:-

Piezoelectric effect

B:-

Electromagnetic induction

C:-Mutual induction

D:-

Capacitance variation

Correct Answer:- Option-B

Question56:-

Semiconductor strain gauges have

A:-Lower sensitivity

B:-

Zero temperature effect

C:-

Higher gauge factor

D:-

Lower accuracy

Correct Answer:- Option-C

Question57:-The standard atmospheric pressure corresponds to

A:-760 mm Hg

B:-

76 mm Hg

C:-760 mm water

D:-760 cm Hg

Correct Answer:- Option-A

Question58:-Piezoelectric pressure transducers are most suitable for

A:-Static pressure measurement

B:-

Dynamic pressure measurement

C:-Vacuum only

D:-

Atmospheric pressure only

Correct Answer:- Option-B

Question59:-

Pirani gauge works on the variation of

A:-Capacitance

B:-

Fluid density

C:-

Magnetic permeability

D:-

Thermal conductivity of gas

Correct Answer:- Option-D

Question60:-Gauge pressure is measured relative to

A:-

Absolute vacuum

B:-

Atmospheric pressure

C:-

Zero pressure

D:-

None of these

Correct Answer:- Option-B

Question61:-Which of the following describes the relationship between fluid velocity and pressure in a restriction according to Bernoulli's principle ?

A:-Velocity and pressure are completely independent of each other

B:-Velocity and pressure are directly related; as velocity increases pressure increases

C:-Velocity and pressure are inversely related; as velocity increases, pressure decreases

D:-Velocity changes do not alter pressure unless the fluid is a gas

Correct Answer:- Option-C

Question62:-What is the SI unit of discharge ?

A:-Gram per minute

B:-Cubic metre per second

C:-Kilogram per cubic metre

D:-Kilogram per second

Correct Answer:- Option-B

Question63:-Reynold's number (Re) is defined fundamentally as the ratio of which two forces ?

A:-Pressure force to Viscous force

B:-Inertia force to Viscous force

C:-Gravitational force to Inertia force

D:-Viscous force to surface tension force

Correct Answer:- Option-B

Question64:-Which type of orifice plate is specifically noted for being bored 'tangential to a circle' to prevent the damming up of solid materials or foreign particles at the bottom of a pipe line ?

A:-Quadrant edge orifice plate

B:-Concentric orifice plate

C:-Segmental Orifice plate

D:-Eccentric orifice plate

Correct Answer:- Option-D

Question65:-Which material is/are used for making flow nozzle ?

A:-Stainless steel

B:-Chrome-Molybdenum steel

C:-Both 1 and 2

D:-Cast Iron

Correct Answer:- Option-C

Question66:-The operating principle of a Pitot Tube is based primarily on measuring the difference between which two pressure points ?

A:-Static pressure and Atmospheric pressure

B:-Upstream pressure and downstream permanent loss pressure

C:-Impact (stagnation) pressure and static pressure

D:-Vapour pressure and Total line head pressure

Correct Answer:- Option-C

Question67:-How does a rotameter (variable-area flow meter) maintain a constant differential pressure across its float while measuring different flow rates ?

A:-By changing the density of the float material dynamically

B:-By using a built-in-spring that compresses as flow increases

C:-By continuously adjusting an external downstream control valve automatically

D:-By utilizing a tapered tube that increases the annular area for fluid flow as the float rises

Correct Answer:- Option-D

Question68:-Which device is classified as an indirect level measurement instrument ?

A:-Sight glass gauge

B:-Dip stick/Dip tape

C:-Hydrostatic pressure transmitter

D:-Hook type level indicator

Correct Answer:- Option-C

Question69:-In a Magnetic float-type level gauge, where is the permanent magnet located ?

A:-Embedded inside the external indicator flags

B:-Sealed inside the internal floating element

C:-Mounted inside the top vent valve

D:-Wrapped around the outside of the bypass pipe column

Correct Answer:- Option-B

Question70:-What is primary safety function of the ball-check mechanism inside a level gauge valve assembly ?

A:-To automatically vent accumulated air from the upper chamber

B:-To instantly shut off fluid flow if the glass tube shatters or breaks

C:-To control the flow rate entering the glass tube to prevent turbulence

D:-To filter out solid scale particles from fouling the glass column

Correct Answer:- Option-B

Question71:-What is the basic standard SI unit of quantity of heat energy ?

A:-Joule

B:-Calorie

C:-Watt

D:-Celsius

Correct Answer:- Option-A

Question72:-Which primary category of thermometers relies strictly on the expansion of solids for its mechanical operating principle ?

A:-Optical pyrometer

B:-Gas thermometers

C:-Bimetallic thermometers

D:-Liquid in glass thermometers

Correct Answer:- Option-C

Question73:-Which component inside a temperature transmitter is specifically responsible for eliminating electrical noise from the raw point sensor signal ?

A:-The mechanical bourdon tube linkage

B:-The output span adjustment pot

C:-The input amplification circuit filter

D:-The reference junction card

Correct Answer:- Option-C

Question74:-Which two temperature scales are explicitly classified as 'absolute scale' system because they utilize absolute zero as their reference point ?

A:-Kelvin and Celsius

B:-Centigrade and Reamur

C:-Rankine and Kelvin

D:-Fahrenheit and Celsius

Correct Answer:- Option-C

Question75:-The operation of gas thermometers depends primarily upon which fundamental physical law ?

A:-Hooke's law of elasticity

B:-Ohm's law of resistance

C:-Faraday's law of Induction

D:-Ideal gas law

Correct Answer:- Option-D

Question76:-Which metal is most commonly used for precision resistance measurement in RTD sensors due to its stability, corrosion resistance and purity ?

A:-Platinum

B:-Iron

C:-Nickel

D:-Copper

Correct Answer:- Option-A

Question77:-Which thermocouple type is composed of Chromel and Constantan alloys and covers a typical measurement span from 0 to 870 degree centigrade ?

A:-S-Type

B:-J-Type

C:-K-Type

D:-E-Type

Correct Answer:- Option-D

Question78:-What is the temperature range of optical pyrometer typically provide an accurate method of measurement ?

A:-Between 1400 and 5000 degree celsius

B:-Between -50 and 200 degree celsius

C:-Between 600 and 3000 degree celsius

D:-Between 0 and 500 degree celsius

Correct Answer:- Option-C

Question79:-Which physical law governs the basic operation principle of a hydraulic actuator system ?

A:-Newton's third law of motion

B:-The Stefan-Boltzman law of radiation

C:-Ohm's law

D:-Pascal's law

Correct Answer:- Option-D

Question80:-What behaviour defines a 'reverse acting' (air-to-open) pneumatic diaphragm actuator ?

A:-An increase in pneumatic control pressure forces the valve stem downwards to close the valve

B:-The actuator runs purely on liquid hydraulic pressures rather than compressed instrument air

C:-The control valve opens wider when air pressure is entirely lost or disconnected

D:-An increase in pneumatic control pressure lifts the valve stem against a spring to open the valve

Correct Answer:- Option-D

Question81:-In which controller the output of primary controller is the setpoint to the secondary controller ?

A:-Ratio controller

B:-Cascade controller

C:-Feedback controller

D:-Feedforward controller

Correct Answer:- Option-B

Question82:-The Ziegler-Nichols method is a popular technique used for

A:-PID controller tuning

B:-Flow measurement

C:-Controller testing

D:-Testing of communication cable

Correct Answer:- Option-A

Question83:-Which ladder diagram represents the equation $Y = A.B$?

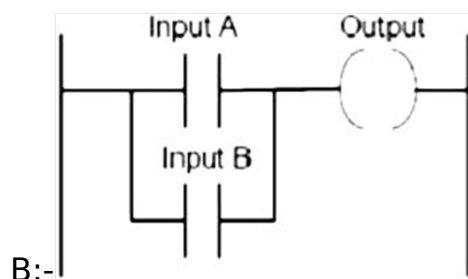
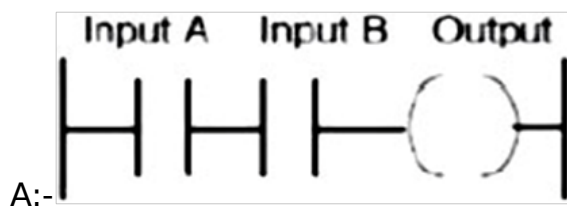

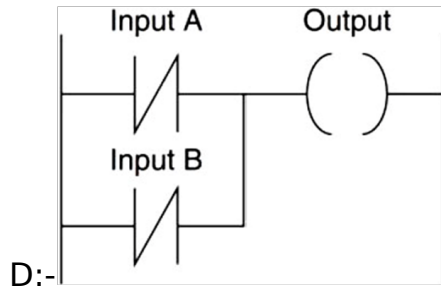
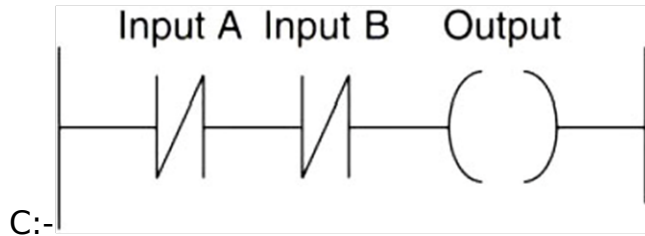

Correct Answer:- Option-A

Question84:-What is the purpose of scan cycle in PLC operation ?

A:-To reduce communication speed

B:-To ensure supply voltage

C:-Sequentially processing inputs logics and outputs

D:-To store data

Correct Answer:- Option-C

Question85:-Full form of HART is

A:-High Accuracy Remote Transformer

B:-Highway Addressable Remote Transducer

C:-High Addressable Relay Transmission

D:-Hybrid Automated Relay Transducer

Correct Answer:- Option-B

Question86:-Which of the following is a input device of a PLC ?

A:-Motor

B:-Alarm

C:-Proximity sensor

D:-Pump

Correct Answer:- Option-C

Question87:-In a proportional controller the proportional gain factor (K_p) increases, the system

A:-Overshoot and undershoot increases

B:-Overshoot and undershoot decreases

C:-Overshoot and undershoot remains constant

D:-No change to the system

Correct Answer:- Option-A

Question88:-What is an 'error signal' in feedback loop ?

A:-The output signal sent to the actuator

B:-The difference between the setpoint and measured value

C:-The electrical noise in the system

D:-The maximum output of the controller

Correct Answer:- Option-B

Question89:-In a feedforward control system which of the following is true ?

I. System in which corrective is taken before disturbances affect the output.

II. Variables are adjusted based on prior knowledge and predictions.

A:-Only I

B:-Only II

C:-Both I and II

D:-None of them

Correct Answer:- Option-C

Question90:-HART Communication uses which type of signals for communication ?

A:-Pneumatic and hydraulic

B:-Analog and digital

C:-Optical and infrared

D:-Mechanical and electrical

Correct Answer:- Option-B

Question91:-Which topology requires a multipoint connection ?

A:-Ring

B:-Bus

C:-Star

D:-Mesh

Correct Answer:- Option-B

Question92:-Two devices are in network if

A:-A process in one device is able to exchange information with a process in another device

B:-A single computer with multiple user accounts

C:-A process is running on both devices

D:-A wireless standard for internet access

Correct Answer:- Option-A

Question93:-RJ-45 is commonly used to connect

A:-UTP cable

B:-STP cable

C:-Both UTP and STP cable

D:-None of them

Correct Answer:- Option-C

Question94:-For a good message transmission the signal to noise ratio should be

A:-High

B:-Low

C:-Zero

D:-Very low

Correct Answer:- Option-A

Question95:-What does the acronym SCADA stand for ?

A:-Supervisory Communication and Data Analysis

B:-Supervisory Control and Data Acquisition

C:-System Control and Data Analysis

D:-Supervisory Control and Data Analysis

Correct Answer:- Option-B

Question96:-In a Distributed control System which of the following is true ?

I. DCS has a layered structure.

II. DCS has a two master controllers.

A:-Only I is true

B:-Only II is true

C:-Both I and II are true

D:-None of the above

Correct Answer:- Option-A

Question97:-Dissolved oxygen concentration indicates

A:-Quality of water

B:-Quality of milk

C:-Quality of nitrogen

D:-Quality of hydrogen

Correct Answer:- Option-A

Question98:-RTP stands for

A:-Remote Transmission Panel

B:-Remote Terminal Panel

C:-Remote Transmission Palette

D:-Remote Terminal Palette

Correct Answer:- Option-A

Question99:-Which field bus communication uses master-slave principle ?

A:-Bluetooth

B:-MODBUS

C:-PROFI BUS

D:-Ethernet

Correct Answer:- Option-B

Question100:-How is pH defined ?

A:-Negative logarithm of hydrogen ion concentration

B:-Ratio of voltage to current

C:-Measure of electrical conductivity

D:-Amount of dissolved oxygen in water

Correct Answer:- Option-A